

Mobile Rugged Tablet PC



ID83

Model : R12ID8M-RTM7GP

Intel® Atom Dual Core N2800 1.86GHz

Features:

- 12.1" High Quality 1024 x 768 Resolution TFT-LCD Panel
- Intel® Atom Dual Core N2800 1.86GHz with Intel® NM10 Chipset
- 1 x SODIMM, Max. 4GB DDR3-1066 (Default 2GB)
- 4W Resistive Touch
- Brightness up to 700 nit enhanced visibility
- Alu-Mg Alloy Housing with Protective Rubber for MIL-STD-810G Shock, Vibration and Drop
- Built-in Wireless / Bluetooth / and GPS module
- Support 3G function (for optional)
- 6 cell, 5200mAh Lithium-Ion Battery Pack
- Low Power consumption CPU only 3.5W

Mechanical Design Drawings

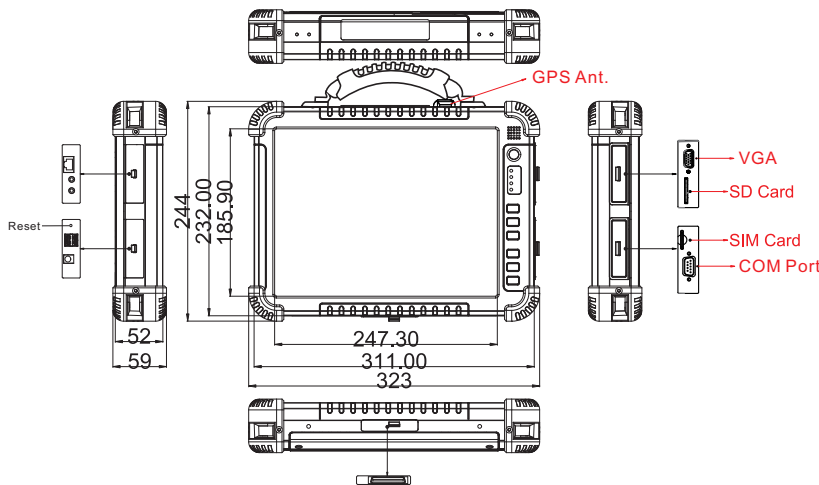

System Specification

- Processor : Intel® Atom Dual Core N2800 1.86GHz
- BIOS : AMI System BIOS
- System Chipset : Intel® NM10 Chipset
- System Memory : 1 x SO-DIMM, Max 4GB DDR3-1066/1333 (Default 2GB)
- LAN Controller : 10/100/1000 Mbps LAN
- Storage : Default 64GB mSATA SSD(max.up to 256GB)
- Audio : 1 x Microphone in, 1 x Line out

Wireless Communication

- WLAN&Bluetooth : 802.11a/b/g/n + 2T2R & Bluetooth 4,0 +Class I combo card(Default)
- WWAN : Built-in 3G module (Optional)
- GPS : U-Blox Neo-6Q

Mechanical and Environment

- Dimensions (W x L x H) : 323 x 244 x 59 mm
- Weight : 3.0 Kg(w/o accessories)
- Operation Temperature : -20~60 (AC mode), -10~50 (Battery mode)
- Operation Humidity : 10% to 90% (non condensing)
- IP Proof : IP54
- Mounting : VESA mount, Vehicle mount
- Shock* : MIL-STD-810G M516.6
- Vibration* : MIL-STD-810G M514.6
- Drop* : MIL-STD-810G M516.6, 4 ft, Free to concrete
- Certifications : CE, FCC ClassB, MIL-810G for Vibration /Shock / Drop / Temp.

Display Specification

- Pixel Number : 1024 x 768
- Brightness : 700cd/m² (typ.)
- Touch (Default) : 4 Wire Resistive

I/O Connectors

- Left I/O Port : 1 x LAN, 2 x USB 2.0, 1 x Audio out, Micro-in Jack, 1 x Power Input Jack, 1 x Reset Button
- Right I/O Port : 1 x COM, 1 x SIM card slot, 1x VGA, 1xSD card slot
- Downside Docking : 1 x Docking connector

In front Control

- Control Button : 1x Menu Key control Brightness, Volume and Battery Status
- LED indicator : Power On/ Off , Battery , HDD Access , Wifi On / Off

Power Management

- Power input : 19V DC
- Power consumption : 11W typ.
- Battery : Li-Ion battery 5200mAh, 11.1V
- Battery Hour : 7 hrs**
- Adapter : 100-240V, 50-60Hz, 19V DC

*Note: this is a simplified drawing and some components are not marked in detail. Please contact our sales representative if you need further product information.
**Note: Measured at dimming LCD brightness. Varies depending on the usage conditions, or when an external device is attached.

Note: All Specifications are subject to change without prior notice!